

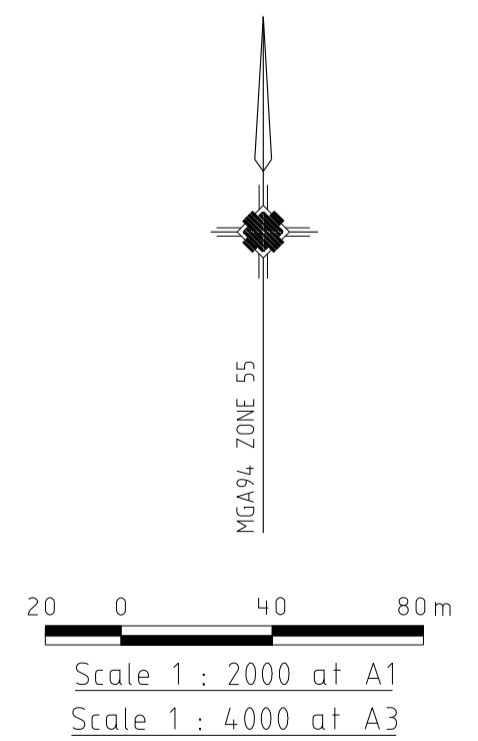

LOT AREAS		
	No. of Lots	Percentage of Lots
Under 300 sq m	38	16.1 %
300 - 399 sq m	71	30.1 %
400 - 499 sq m	96	40.7 %
Over 499 sq m	31	13.1 %
<b>TOTAL</b>	<b>236</b>	<b>100.0 %</b>

STAGING			
Stage	No. of Lots	% of Total	Area
1	55	23.3 %	3.28 ha
2	42	17.8 %	2.17 ha
3	50	21.2 %	3.46 ha
4	53	22.5 %	2.94 ha
5	36	15.2 %	2.48 ha
<b>Total</b>	<b>236</b>	<b>100.0 %</b>	<b>14.34 ha</b>

**Notes:**  
 This plan is prepared for conceptual and marketing purposes only.  
 All areas and dimensions are subject to verification by survey.  
 Lot frontages and depths shown include plays.  
 This plan is subject to survey, formal engineering design and referral authority approval.



DATE	REVISION	DETAILS	AUTHORISED	SCALE:	1 : 2000 at A1
20/5/13	A	Minor layout changes and notations added.	M.N.D.	DATE PRINTED:	20/05/2013
				LEVEL DATA:	---
				LEVEL DATUM:	---
				PROJECT No.:	36390
				DRAWN:	J.A.C. DATE: 16/5/13
				DESIGNED:	M.N.D. DATE: 16/5/13
				AUTHORISED:	M.N.D. DATE: 16/5/13

MORNINGTON  
 5 Main Street,  
 Phone: (03) 5975 4444  
 Fax: (03) 5975 3916

MELBOURNE  
 The Melbourne Suite 2,  
 250 St. Kilda Rd.  
 Phone: (03) 9697 8000  
 Fax: (03) 9697 8099



WYNDHAM CITY COUNCIL		PLAN NUMBER
<b>SATTERLEY PROPERTY GROUP</b> 990 SAYERS ROAD TARNET		36390CP-E
<b>CONCEPT PLAN</b> SECTION 96A EASTERN PRECINCT		REVISION C
		SHEET 1 OF 1

COPYRIGHT - THESE DOCUMENTS AND THE INTELLECTUAL PROPERTY PRODUCED SHALL REMAIN VESTED WITH WATSONS PTY LTD. IN ACCORDANCE WITH AGREED FEES THE CLIENT SHALL HAVE A LICENSE TO USE THIS PRODUCT FOR THE PURPOSE OF COMPLETING THE PROJECT. THIS PLAN IS NOT TO BE MANIPULATED WITHOUT THE PERMISSION OF WATSONS PTY LTD.